

# Purification of Parthenolide in Feverfew by Supercritical Fluid Extraction and Supercritical Fluid Chromatography with Evaporative Light Scattering Detection

Yoshiteru Horikawa, Atsushi Tsukamoto, Masao Bounoshita, Toshihiko Miyaji  
JASCO Corporation, Tokyo, Japan  
JASCO global homepage: <http://www.jascoinc.com>

## 1. Introduction

Evaporative light scattering detector (ELSD) can be used for the detection of the compounds which do not have any specific properties such as UV absorption due to its wide range of applicability except for volatile compounds. However, when ELSD is used in supercritical fluid chromatography (SFC), the detection parameters in ELSD should be optimized because the chromatogram shows specific behavior in SFC.

In this presentation, we measured the behavior of chromatogram by changing those parameters. Parthenolide (Figure 2) which is reported to be active principle<sup>1)</sup>.

In this presentation, we tried to purify Parthenolide in feverfew by Supercritical fluid extraction (SFE) and the subsequent SFC with ELS detection

## 2. Experimental

### 2.1 Apparatus

**Apparatus.** Figure 3 shows the appearance of JASCO Semi-preparative SFC/PDA/ELSD system (all from JASCO Co., Tokyo, Japan) used in this experiment.

Figure 4 shows the schematic diagram of the SFC/PDA/ELSD System.

Figure 5 shows the flow diagram of the SFE System.

Figure 6 shows the Micro Cyclone Separator (MCS).

**Materials and Chemicals.** Columns, SFCpak SIL-5, 4.6 mm ID x 250 mm and SFCpak SIL-5SP, 10.0 mm ID x 250 mm were purchased from JASCO Co., Tokyo, Japan.

Carbon dioxide (99.98 %) was supplied by TAIYO NIPPON SANCO Co., Ltd, Tokyo, Japan. HPLC-grade methanol which was used as modifier and make up solvent and Caffeine were purchased from Wako Pure Chemicals, Osaka, Japan. Ethyl p-Hydroxybenzoate (Ethylparaben) was purchased from TOKYO CHEMICAL INDUSTRY Co., Tokyo, Japan. Parthenolide was purchased from Sigma-Aldrich Co., USA. Air-dried Feverfew was made in USA.



Figure 3 JASCO Semi-preparative SFC/PDA/ELSD System

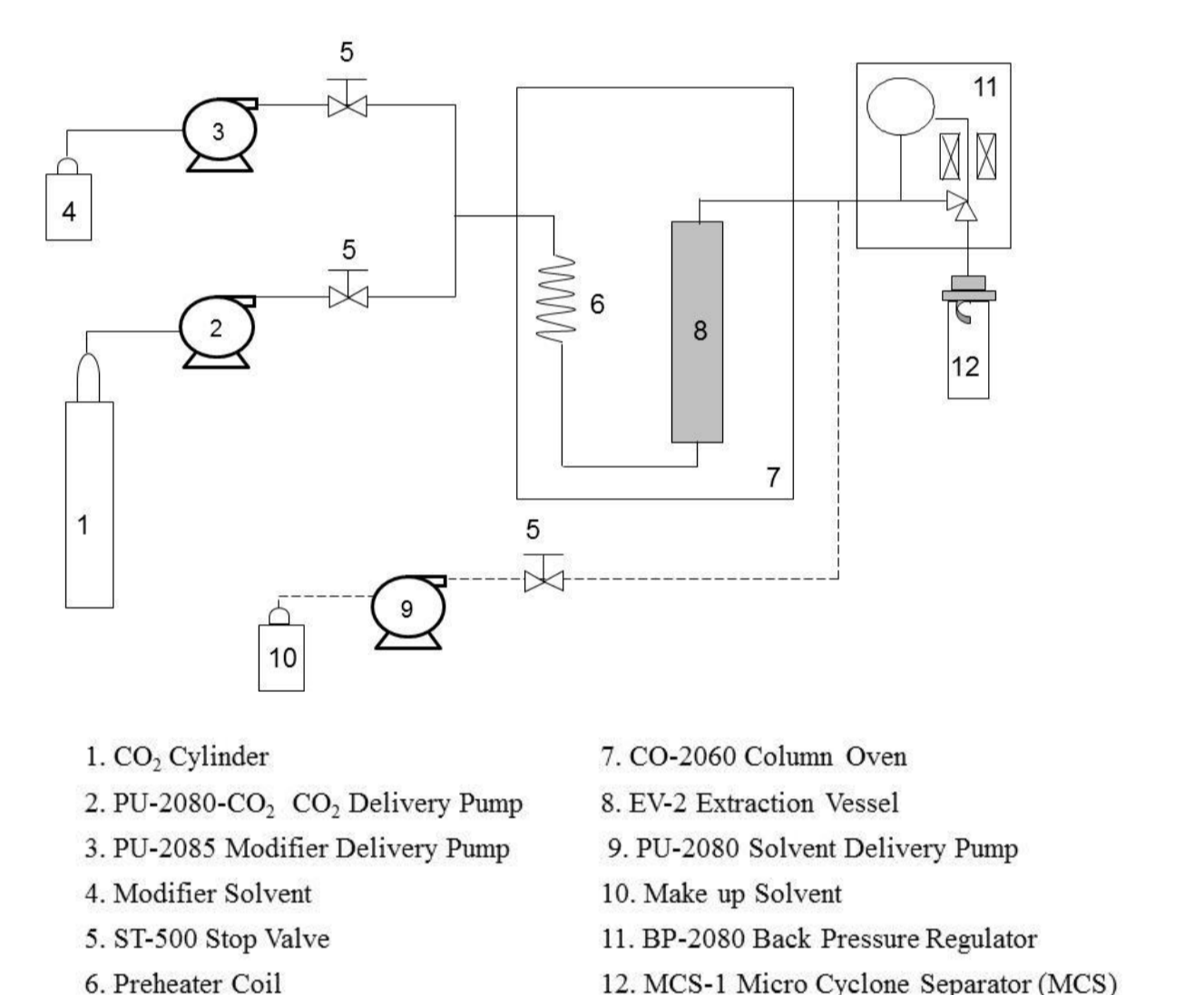

Figure 5. Flow diagram of the JASCO SFE System

## 3. Results and Discussion

### 3.1 ELSD Parameters of SFC

First of all, the parameters for the gas flow rate, evaporator temperature and nebulizer temperature were optimized in SFC. These parameter are specific parameter for ELSD. Ethylparaben (Figure 7) and caffeine (Figure 8) were used as standard sample.

#### 3.1.1 Effect of Gas Flow Rate

Figure 9 shows the chromatograms of Ethylparaben and caffeine when the gas flow rate is changed.

Figure 10 shows the effect of gas flow rate on the areas for Ethylparaben and caffeine.

The areas for Ethylparaben and caffeine were decreased as the gas flow rate was increased. In the case of SFC, CO<sub>2</sub> enters in the detector probe, and the gas flow rate is the total of CO<sub>2</sub> and gas flow rates. For this reason, it is thought that the sensitivity becomes higher as the gas flow rate is small.

#### 3.1.2 Effect of Evaporator Temperature

Figure 11 shows the chromatograms of Ethylparaben and caffeine when the evaporator temperature is changed.

Figure 12 shows the effect of evaporator temperature on the areas for Ethylparaben and caffeine.

The evaporator temperature depends on the volatility of sample. The area for Ethylparaben, which is a semi-volatile organic compound, was decreased as the temperature was increased. On the other hand, the area for caffeine, which has low volatility, was almost the same when the temperature was 30 °C or more.

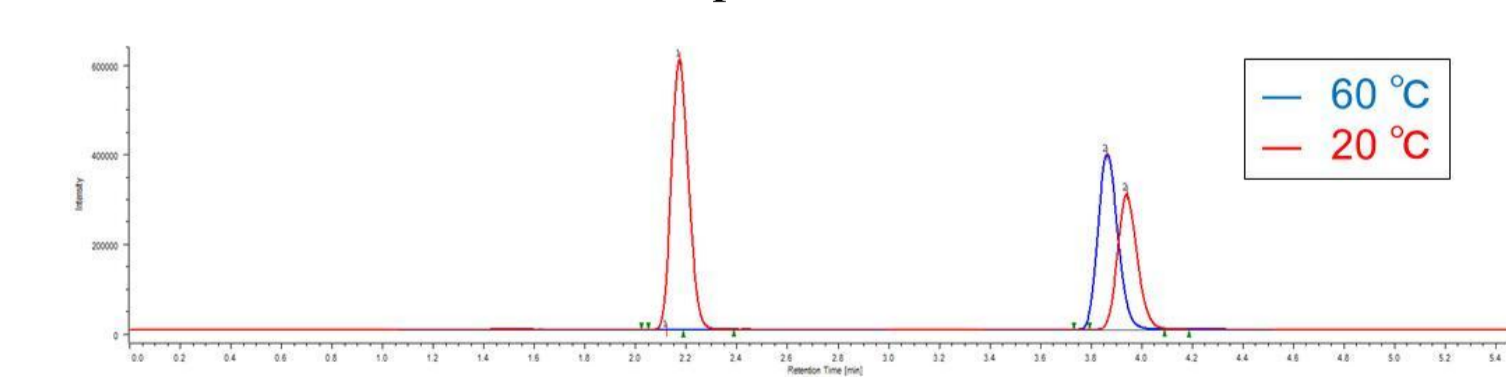

Figure 11. Chromatograms of Ethylparaben and Caffeine when the evaporator temperature is changed  
The separation conditions are: column: SFCpak SIL-5 (4.6 mm ID x 250 mm, 5 μm); CO<sub>2</sub> flow rate: 2 mL/min at -10°C; modifier: methanol @ flow rate 0.5 mL/min; make up solvent: methanol @ flow rate 0.5 mL/min; pressure: 20 MPa; column temperature: 40 °C; ELSD evaporator temperature: 20, 60 °C; nebulizer temperature: 40 °C; Gas Flow 0.9 SLM; injection volume: 5 μL; Splitter : I.D. 50 μm x 505 mm; Sample: Ethylparaben and Caffeine (1mg/mL in MeOH.)

#### 3.1.3 Effect of Nebulizer Temperature

Figure 13 shows the effect nebulizer temperature on the areas for Ethylparaben and caffeine.

The areas were not changed as the temperature was changed. This shows that the nebulizer temperature is not effected on the areas for these samples.



Figure 13. Effect of nebulizer temperature  
The separation conditions are: column: SFCpak SIL-5 (4.6 mm ID x 250 mm, 5 μm); CO<sub>2</sub> flow rate: 2 mL/min at -10°C; modifier: methanol @ flow rate 0.5 mL/min; make up solvent: methanol @ flow rate 0.5 mL/min; pressure: 20 MPa; column temperature: 40 °C; ELSD evaporator temperature: 40 °C; nebulizer temperature: 20, 30, 40, 50, 60 °C; nebulizer temperature : 40 °C; Gas Flow 0.9 SLM; injection volume: 5 μL; Splitter : I.D. 50 μm x 505 mm; Sample: Ethylparaben and Caffeine (1mg/mL in MeOH.)



Figure 1. Feverfew

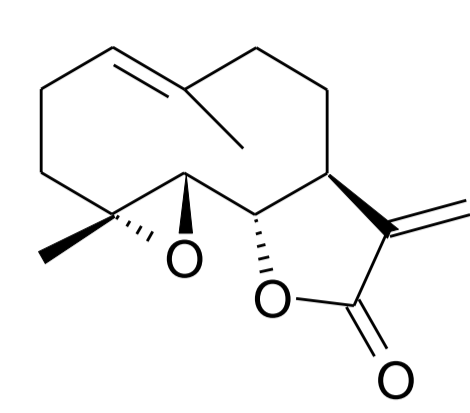

Figure 2. Structure of Parthenolide

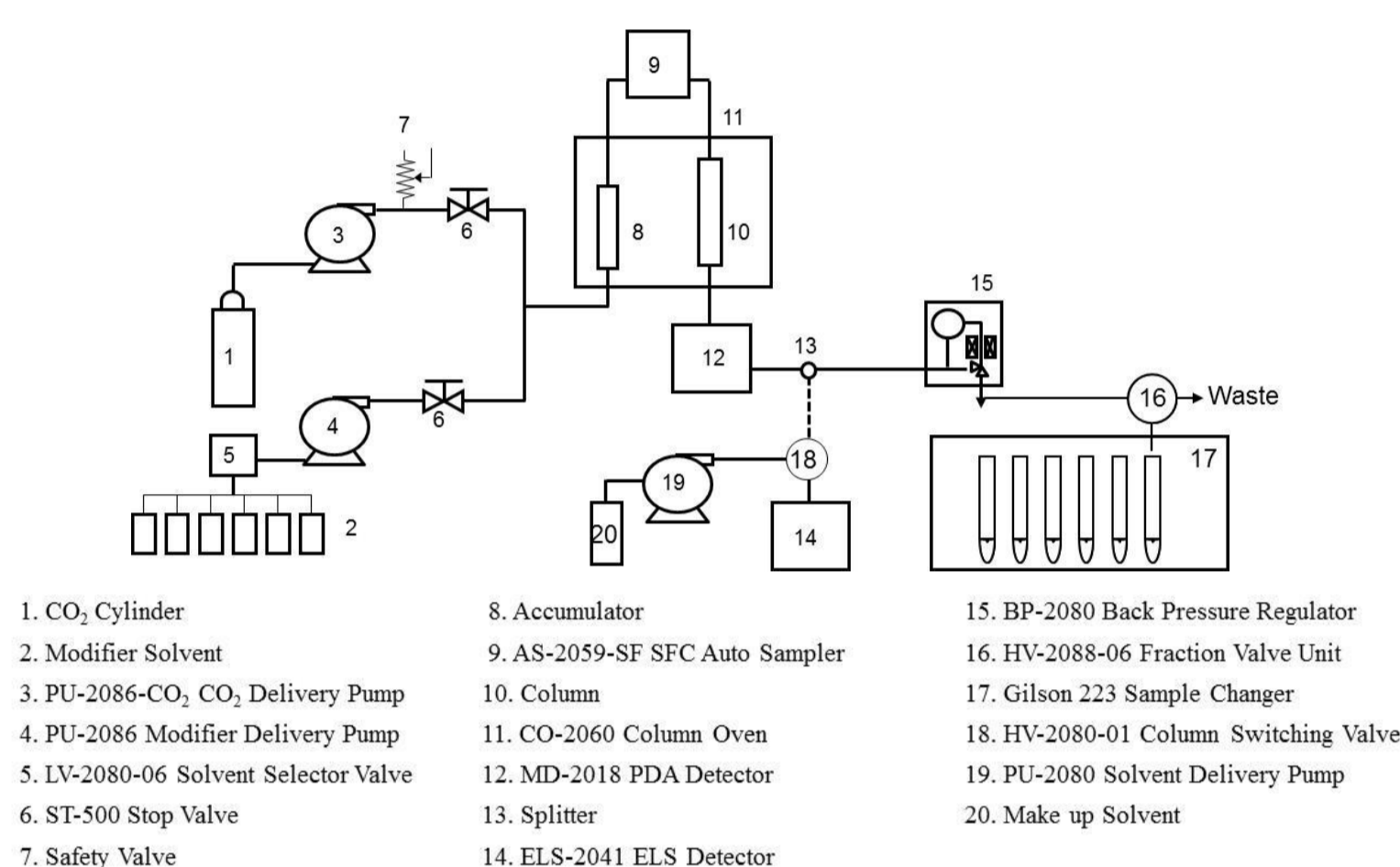

Figure 4. Schematic diagram of the JASCO Semi-preparative SFC/PDA/ELSD System



Figure 6. Micro Cyclone Separator

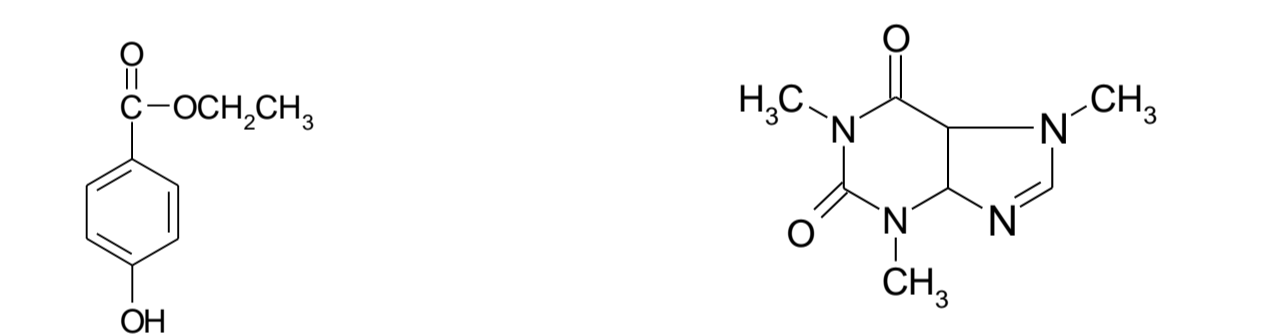

Figure 7. Structure of Ethylparaben

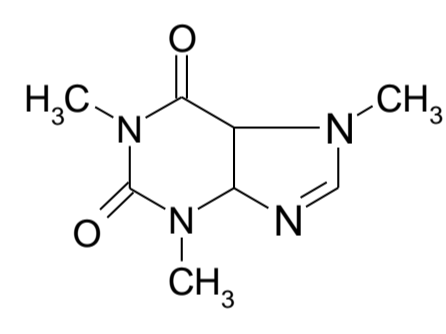

Figure 8. Structure of Caffeine

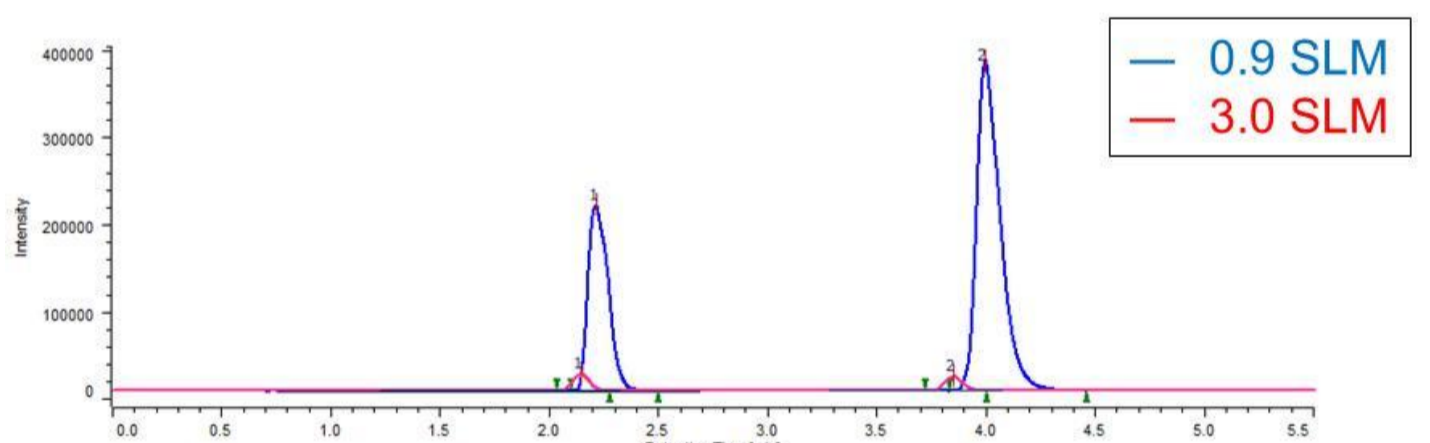

Figure 9. Chromatograms of Ethylparaben and Caffeine when the gas flow rate is changed  
The separation conditions are: column: SFCpak SIL-5 (4.6 mm ID x 250 mm, 5 μm); CO<sub>2</sub> flow rate: 2 mL/min at -10°C; modifier: methanol @ flow rate 0.5 mL/min; make up solvent: methanol @ flow rate 0.5 mL/min; pressure: 20 MPa; column temperature: 40 °C; ELSD evaporator temperature: 40 °C; nebulizer temperature: 40 °C; Gas Flow 0.9, 3.0 SLM; injection volume: 5 μL; Splitter : I.D. 50 μm x 505 mm; Sample: Ethylparaben and Caffeine (1mg/mL in MeOH.)

Figure 10 shows the effect of gas flow rate on the areas for Ethylparaben and caffeine. The areas for Ethylparaben and caffeine were decreased as the gas flow rate was increased. In the case of SFC, CO<sub>2</sub> enters in the detector probe, and the gas flow rate is the total of CO<sub>2</sub> and gas flow rates. For this reason, it is thought that the sensitivity becomes higher as the gas flow rate is small.

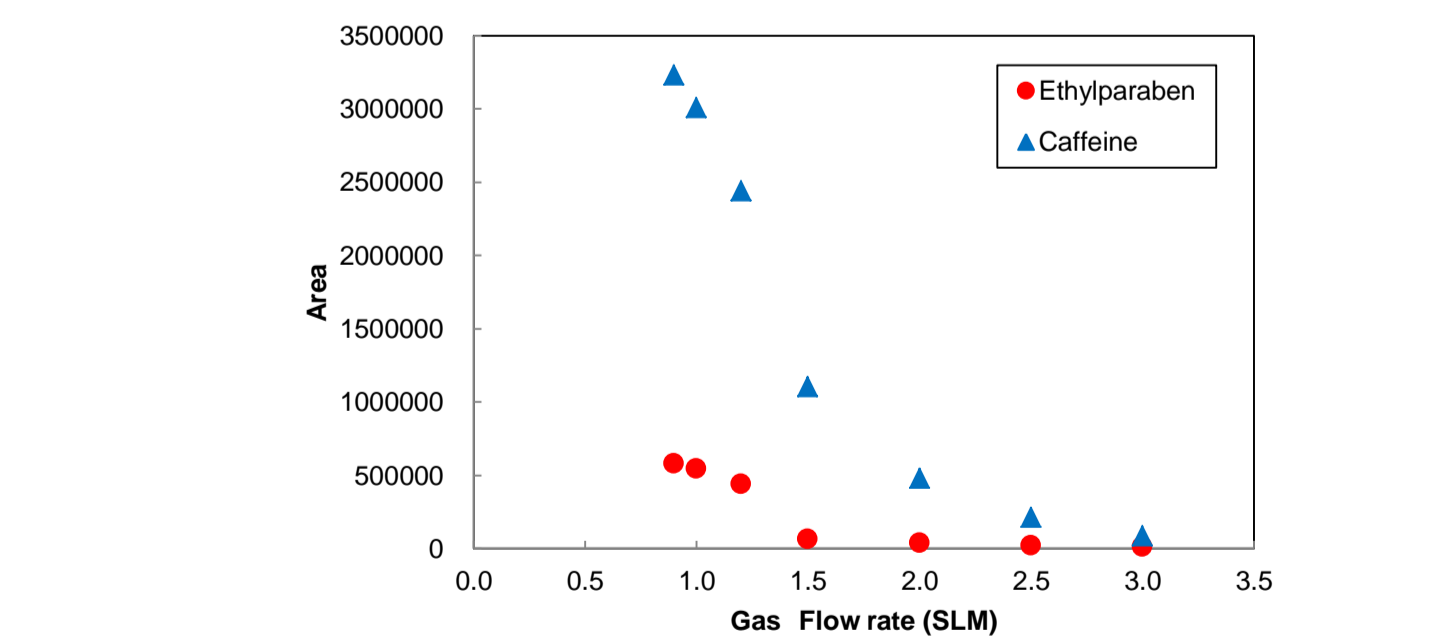

Figure 10. Effect of gas flow rate  
The separation conditions are: column: SFCpak SIL-5 (4.6 mm ID x 250 mm, 5 μm); CO<sub>2</sub> flow rate: 2 mL/min at -10°C; modifier: methanol @ flow rate 0.5 mL/min; make up solvent: methanol @ flow rate 0.5 mL/min; pressure: 20 MPa; column temperature: 40 °C; ELSD evaporator temperature: 40 °C; nebulizer temperature: 40 °C; Gas Flow 0.9, 1.0, 1.2, 1.5, 2.0, 2.5, 3.0 SLM; injection volume: 5 μL; Splitter : I.D. 50 μm x 505 mm; Sample: Ethylparaben and Caffeine (1mg/mL in MeOH.)

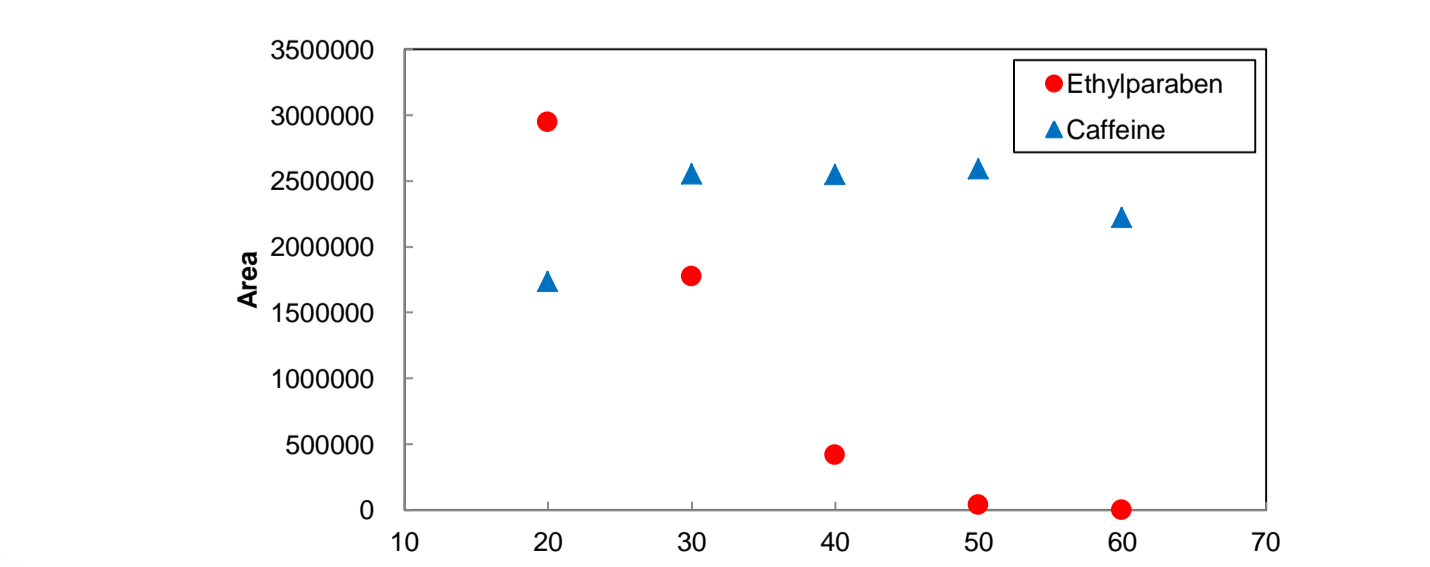

Figure 12. Effect of evaporator temperature  
The separation conditions are: column: SFCpak SIL-5 (4.6 mm ID x 250 mm, 5 μm); CO<sub>2</sub> flow rate: 2 mL/min at -10°C; modifier: methanol @ flow rate 0.5 mL/min; make up solvent: methanol @ flow rate 0.5 mL/min; pressure: 20 MPa; column temperature: 40 °C; ELSD evaporator temperature: 20, 30, 40, 50, 60 °C; nebulizer temperature : 40 °C; Gas Flow 0.9 SLM; injection volume: 5 μL; Splitter : I.D. 50 μm x 505 mm; Sample: Ethylparaben and Caffeine (1mg/mL in MeOH.)

### 3.2 Effect of Splitter Length

In the case of ELSD used for SFC, a splitter is used. Because all volume of sample stream cannot be entered into the detector probe. A typical splitter is made by capillary tube. A part of sample stream is split by this and introduced into the detector probe. The split ratio is decided by the inner diameter and length of capillary tube. However, it varies with the temperature, pressure and flow rate at that time.

Figure 14 shows the effect of splitter length on the areas for Ethylparaben and caffeine.

The area for caffeine became smaller as the length of the splitter was longer. This comes from the increase of tubing resistance. On the other hand, the area for Ethylparaben became small when the length was 280mm. It is assumed that the CO<sub>2</sub> flow rate is increased and the sensitivity becomes smaller as shown in Section 3.1.1.

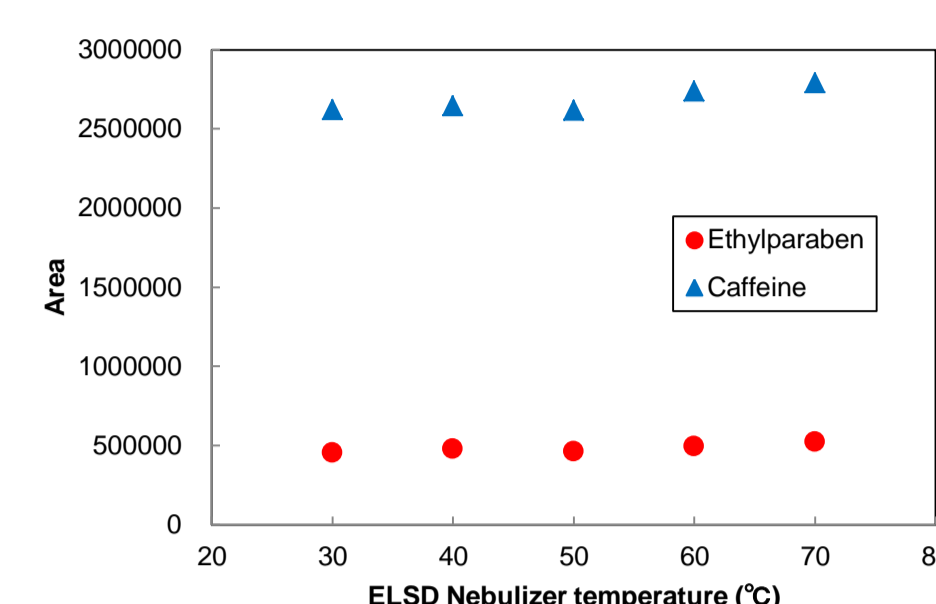

Figure 13. Effect of Nebulizer temperature  
The separation conditions are: column: SFCpak SIL-5 (4.6 mm ID x 250 mm, 5 μm); CO<sub>2</sub> flow rate: 2 mL/min at -10°C; modifier: methanol @ flow rate 0.5 mL/min; make up solvent: methanol @ flow rate 0.5 mL/min; pressure: 20 MPa; column temperature: 40 °C; ELSD evaporator temperature: 40 °C; nebulizer temperature: 30, 40, 50, 60, 70 °C; Gas Flow 0.9 SLM; injection volume: 5 μL; Splitter : I.D. 50 μm x 505 mm; Sample: Ethylparaben and Caffeine (1mg/mL in MeOH.)

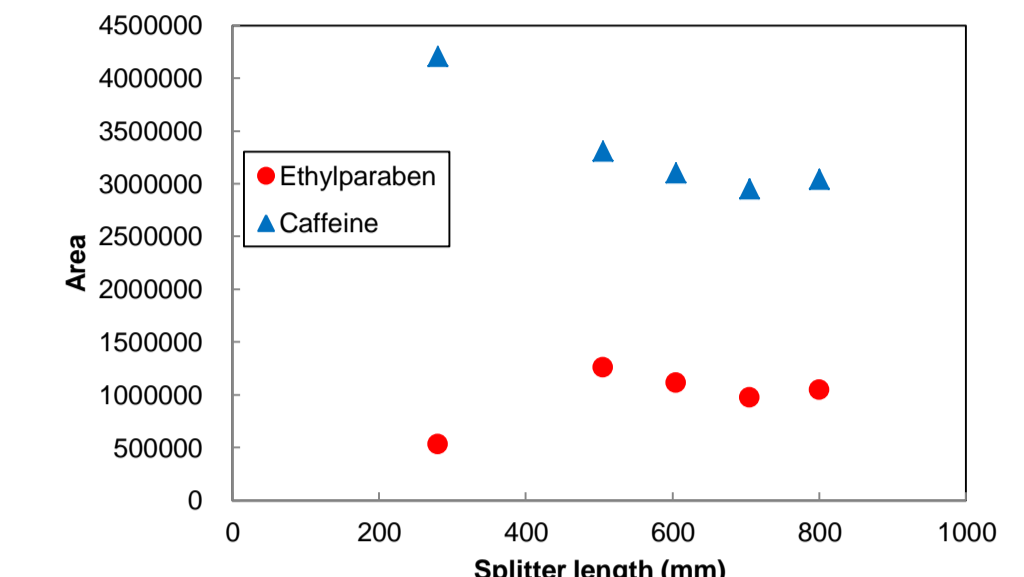

Figure 14. Effect of Splitter length  
The separation conditions are: column: SFCpak SIL-5 (4.6 mm ID x 250 mm, 5 μm); CO<sub>2</sub> flow rate: 2 mL/min at -10°C; modifier: methanol @ flow rate 0.5 mL/min; make up solvent: methanol @ flow rate 0.5 mL/min; pressure: 20 MPa; column temperature: 40 °C; ELSD evaporator temperature: 40 °C; nebulizer temperature: 40 °C; gas flow 0.9 SLM; injection volume: 5 μL; Splitter : I.D. 50 μm x 280, 505, 605, 705, 805 mm; Sample: Ethylparaben and Caffeine (1mg/mL in MeOH.)

### 3.3 Effect of Make up Pump Flow Rate

In the case of SFC, the solvent exhausted from the splitter outlet in the state of the aerosol because there is CO<sub>2</sub>. The dissolubility of the sample falls, and there is a possibility that the sample blockades it in the tube because it becomes CO<sub>2</sub> of the gas from supercritical fluid. Therefore, protect the blockage of a high concentration sample at the time of preparative SFC and the stability of detection can be prevented by flowing the make up solvent. Figure 15 shows the relation of the area of the Ethylparaben and the caffeine when make up pump flow rate was changed. Flow rate went up at time when the make up solvent was not flowed and the sensitivity goes up. However, flow rate increased, the area decreased afterwards. It seems that flow rate is high, the liquid drop in ELSD has caused evaporation shortage.

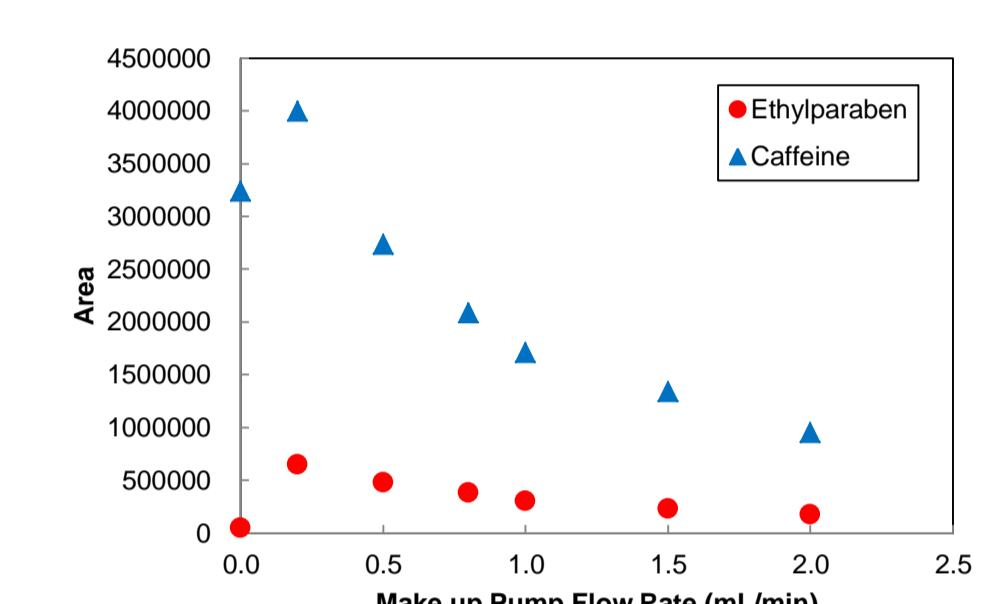

Figure 15. Effect of make up pump flow rate  
The separation conditions are: column: SFCpak SIL-5 (4.6 mm ID x 250 mm, 5 μm); CO<sub>2</sub> flow rate: 2 mL/min at -10°C; modifier: methanol @ flow rate 0.5 mL/min; make up solvent: methanol @ flow rate 0, 0.2, 0.5, 0.8, 1.0, 1.5, 2.0 mL/min; pressure: 20 MPa; column temperature: 40 °C; ELSD evaporator temperature: 40 °C; nebulizer temperature: 40 °C; gas flow 0.9 SLM; injection volume: 5 μL; Sample: Ethylparaben and Caffeine (1mg/mL in MeOH.)

## Summary of ELSD parameters with SFC

#### • Gas flow rate

Low flow rate provides high sensitivity.  
Optimum gas flow rate: 0.8-1.0 SLM

#### • Evaporator Temperature

The evaporator temperature depends on the volatility of the sample.  
In the case of ELS-2041, the sample with high volatility can detect.  
Optimum evaporator temperature 20-40 °C

#### • Nebulizer temperature

The nebulizer temperature does not affect on the sensitivity.

#### • Splitter length

The sensitivity changes by changing the length of the splitter.  
However, it is decreased by the CO<sub>2</sub> flow rate. It depends on the sample.

#### • Make up pump flow rate

Make up solvent should be added for Preparative SFC/ELSD to prevent clogging the tubing.

## 3.4 Purification of Parthenolide in Feverfew by Supercritical Fluid Extraction and Supercritical Fluid Chromatography

### 3.4.1 Feverfew by Supercritical fluid extraction

Feverfew was extracted using the SFE system shown in Figure 4, referring to the Reference<sup>2)</sup>. The SFE conditions are shown in Table I. The preparation after the extraction was shown in Figure 16.

Table I. SFE Condition	
Sample:	Feverfew 1.0 g
Extraction Vessel:	10mL, I.D. 10 mm x 127 mm
CO <sub>2</sub> Flow Rate:	3.0 mL/min
Make up Solvent Flow Rate:	0.3 mL/min (MeOH)
Temperature:	45 °C
Pressure:	30 MPa
Extraction Time:	60 min

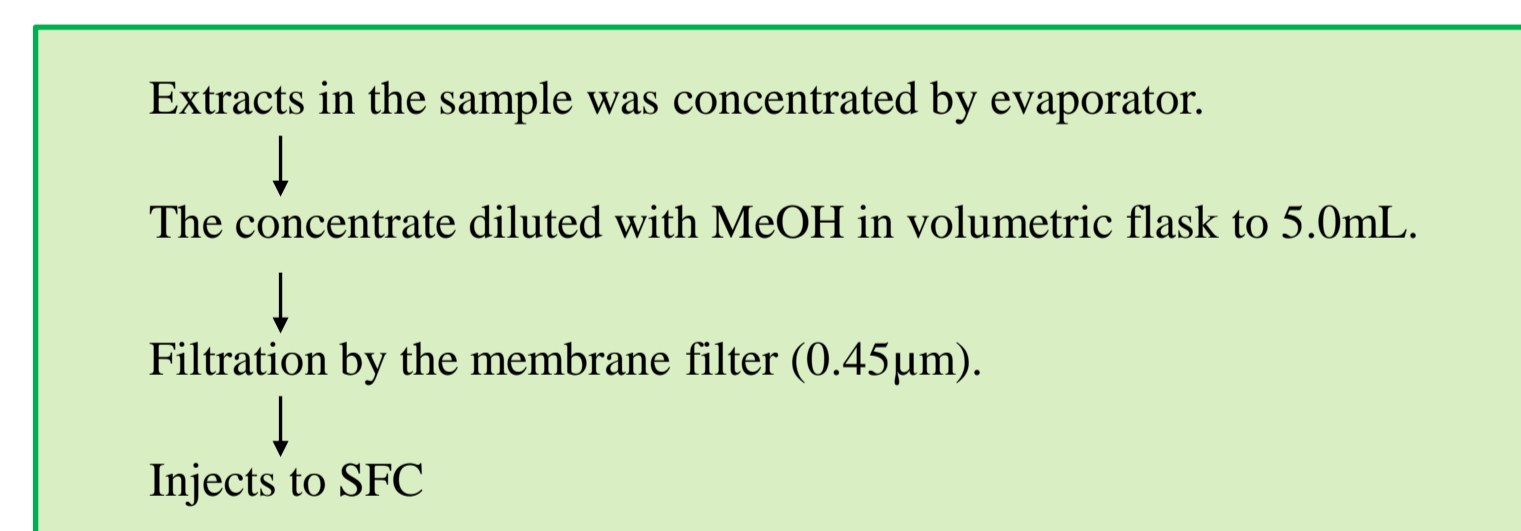

Figure 16 Preparation Flow Sheet

### 3.4.2 Purification of Parthenolide by Supercritical Fluid Chromatography

The sample extracted by SFE and pre-treated was injected to SFC and Parthenolide in the sample was fractionated by semi-preparative SFC. Figure 17 shows the chromatogram of the exacts in Feverfew. The peak shown in red rectangle was fractionated.

The fraction obtained in Figure 17 was analyzed and identified by analytical SFC. Figure 18 shows the chromatogram.

By comparing the peak area with that for the standard sample of Parthenolide, we confirmed that 0.03mg/g of Parthenolide was collected.

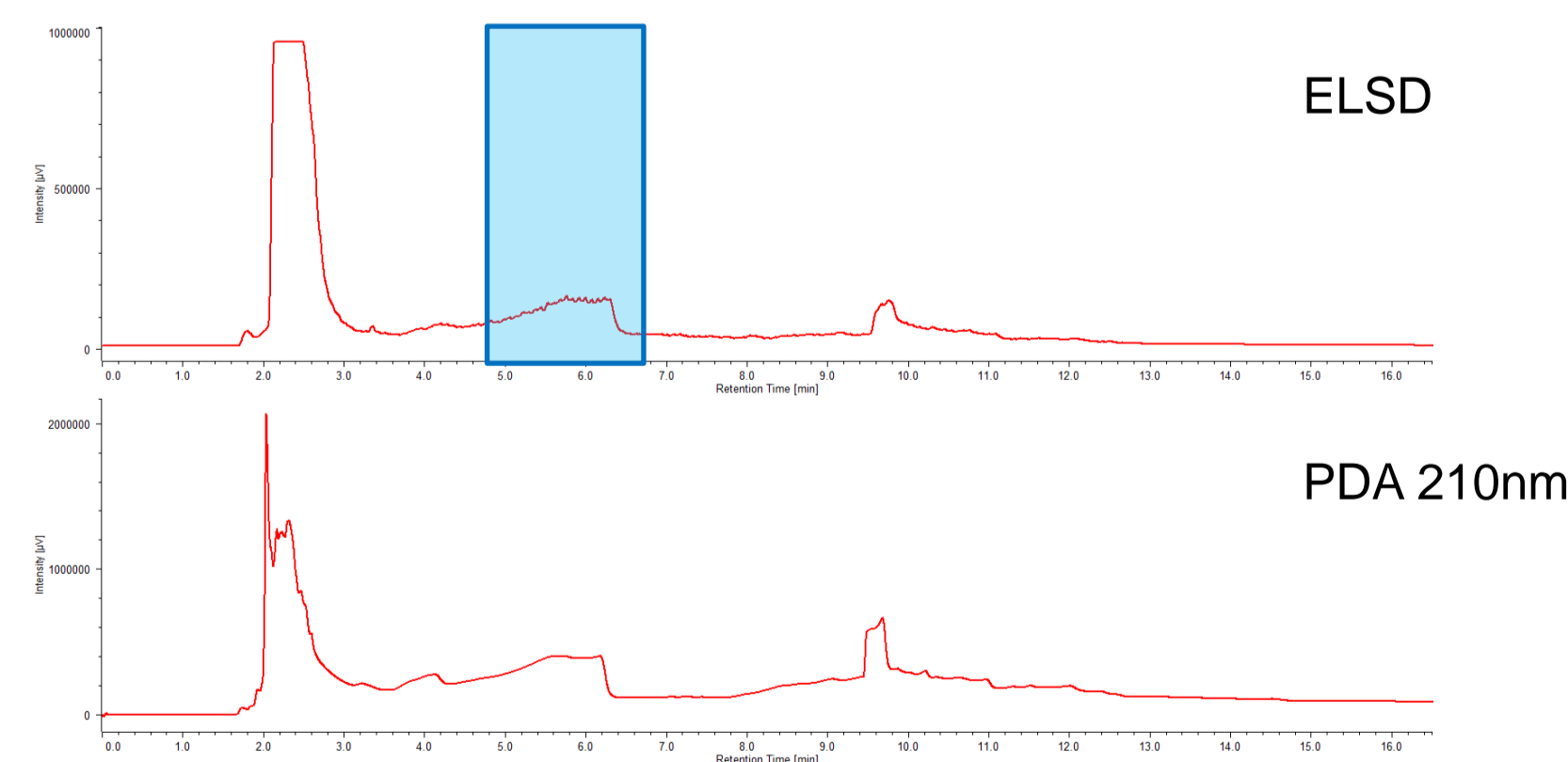

Figure 17. Chromatogram of the extract in Feverfew  
The separation conditions are: column: SFCpak SIL-5SP (10 mm ID x 250 mm, 5 μm); CO<sub>2</sub> flow rate: 10 mL/min at -10°C; modifier: methanol @ flow rates 0.3 0.73 1.5 mL/min 0 7.2 7.3 min make up solvent: methanol @ flow rate 0.5 mL/min; pressure: 20 MPa; column temperature: 40 °C; ELSD evaporator temperature: 40 °C; nebulizer temperature: 40 °C; gas flow 0.9 SLM; Splitter : I.D. 25 μm x 505 mm; injection volume: 500 μL; Sample: the concentrated exact in Feverfew

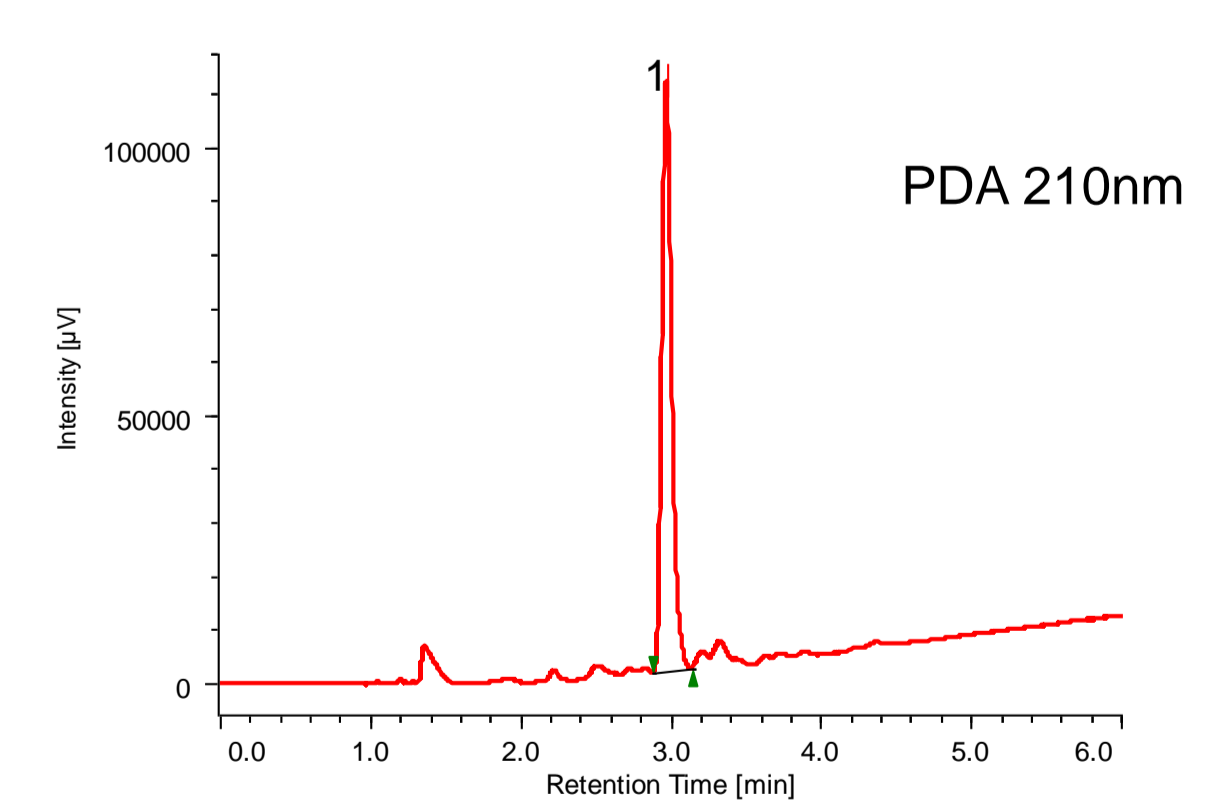

Figure 18. Chromatogram of the fraction  
The separation conditions are: column: SFCpak SIL-5 (4.6 mm ID x 250 mm, 5 μm); CO<sub>2</sub> flow rate: 3.0 mL/min at -10°C; modifier: methanol @ flow rates 0.2 0.38 mL/min 0 6.0 min pressure: 20 MPa; column temperature: 40 °C; injection volume: 5 μL; Sample: the fraction

## 4. Conclusion

- We could optimized the ELS detection parameters for SFC because the chromatogram shows specific behavior in SFC.
- Extracts from Feverfew was performed by Supercritical fluid extraction and Parthenolide was fractionated from the extracts by SFC with ELS detection. 0.03mg/g. of Parthenolide was collected.

## References

- W. A. Groenewegen, D. W. Knight and S. Heptinstall, *J. Pharm. Pharmacol.*, 38, 709 (1986)
- R. M. Smith, M. D. Burford, *J. Chromatography*, 627, 255-261 (1992)